



BENEDRIVE

Benefit Your Drive, Benefit Your Life ...

Company Introduction:



Benedrive is a customer orientated manufacturer for high-tech Traffic Safety Products and Outdoor lighting. After ten years efforts, Benedrive has established a good reputation in OEM/ODM projects for quality and customer service. We are concentrated to provide you competitive price, innovative design, and high quality.

We are specialized in:

Traffic facilities, work zone protection series, architectural lights, aviation/navigation lights and household green lights.

Our Value is customer first. We start from the customer needs. Our way of working is flexible to make sure that the customer is given the best service. We treat all of our customers and partners, both internal and external, with the same respect.

– People in focus

Our way of working is based on honesty and fair play. Respect for the individual, mutual trust and concern are a natural part of our social relations.

– Entrepreneurship and drive for achievement

We take the initiative; we have the courage, and take the responsibility. We are committed to reaching the goals. At the same time, we are open to new challenges. We find solutions of efficient operation. We improve ourselves constantly.

– Passion for excellence

We are devoted to the quality of our products, services and our way of working. We provide our best expertise to the customer. We are creating innovative solutions.

Our dreams: A Green Safer World, A Green Safer Home!

Enterprise Introductions

HONGKONG COMPANY



SHENZHEN FACTORY



PRODUCTS CERTIFICATIONS



Factory & Production Viewing:

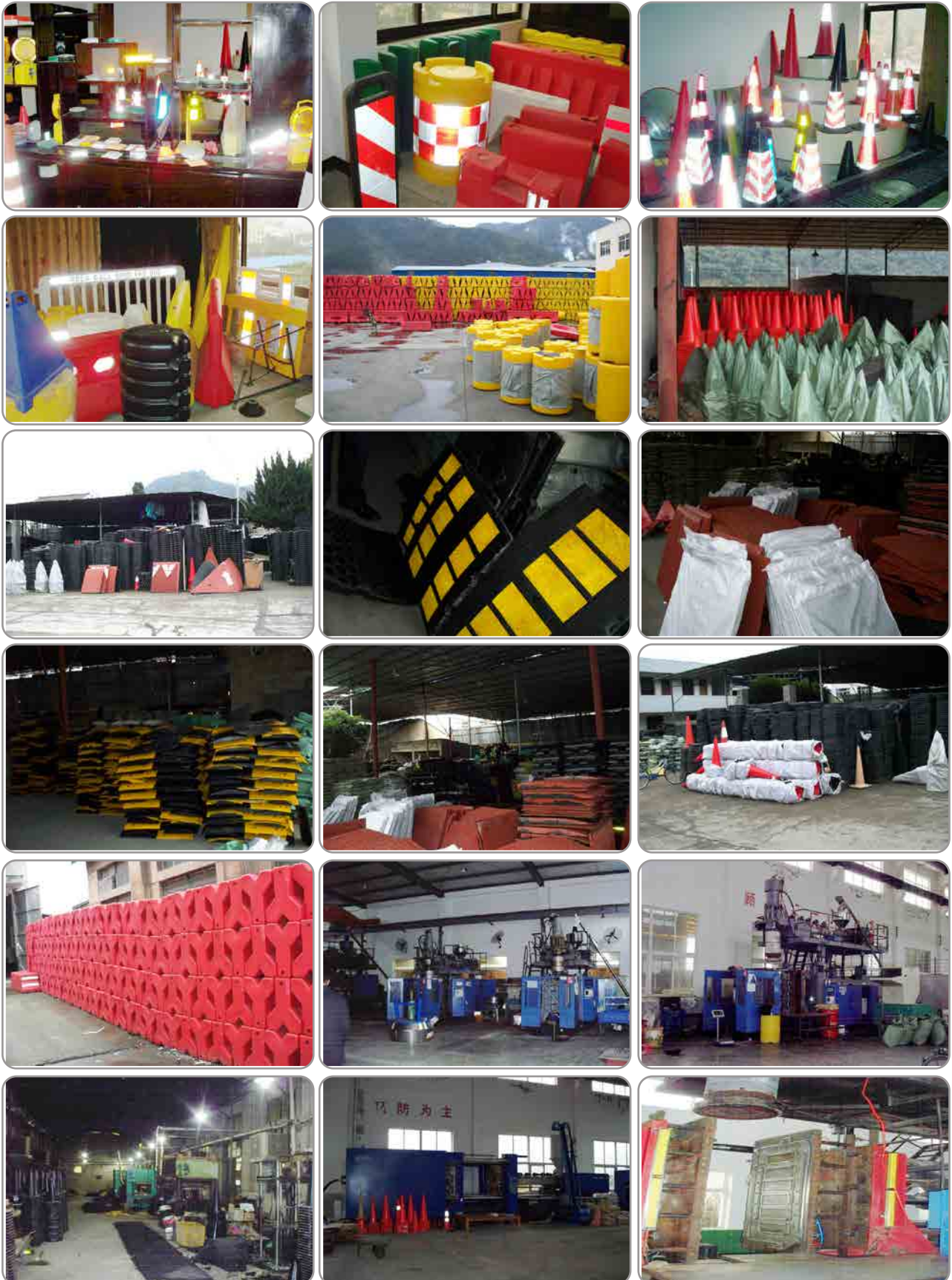

1. Traffic Facilities:

1.1. SOLUTIONS:

1.1.1. - Safety Crossing Solutions



1.1.2. - Intersections Guidance Solutions



1.1.3. - Tunnel Guidance Solutions



1.1.4. - Safety Islands & Traffic Circle Solutions



1.1.5. - Cycleway Solutions



1.2. Solar Traffic Lane Markers

1.2.1. - Embedded type



1.2.2. - Raised Plastic type



1.2.3. - Raised Aluminum type



1.2.4. - Remote Controlled type



1.2.5. - GPS controlled type



1.3. Wired Powered Traffic Lane Markers













1.4. Standard Road Reflectors



1.5. Solar Traffic Signs



Contents

1.6. Solar Traffic Warning Lamps	
1.6. Traffic Lights & Series	
1.7. Traffic Bollards	
1.8. Traffic Delineators and Deviders	
1.9. Road Marking Machines	
2. WorkZone Safety Series:	
2.1. Portable Speed Bumps	
2.2. Sequential Lamps	
2.3. Traffic Arrow Boards	
2.4. Portable Warning Signs	
2.5. Solar Flashing Lamps	
2.6. Traffic Cones	
2.7. Road Warning Bencons	
2.8. Speed Bumps	
2.5. Road Barriers and Barricades	
2.5. Temporary Signs	

Item No: B06

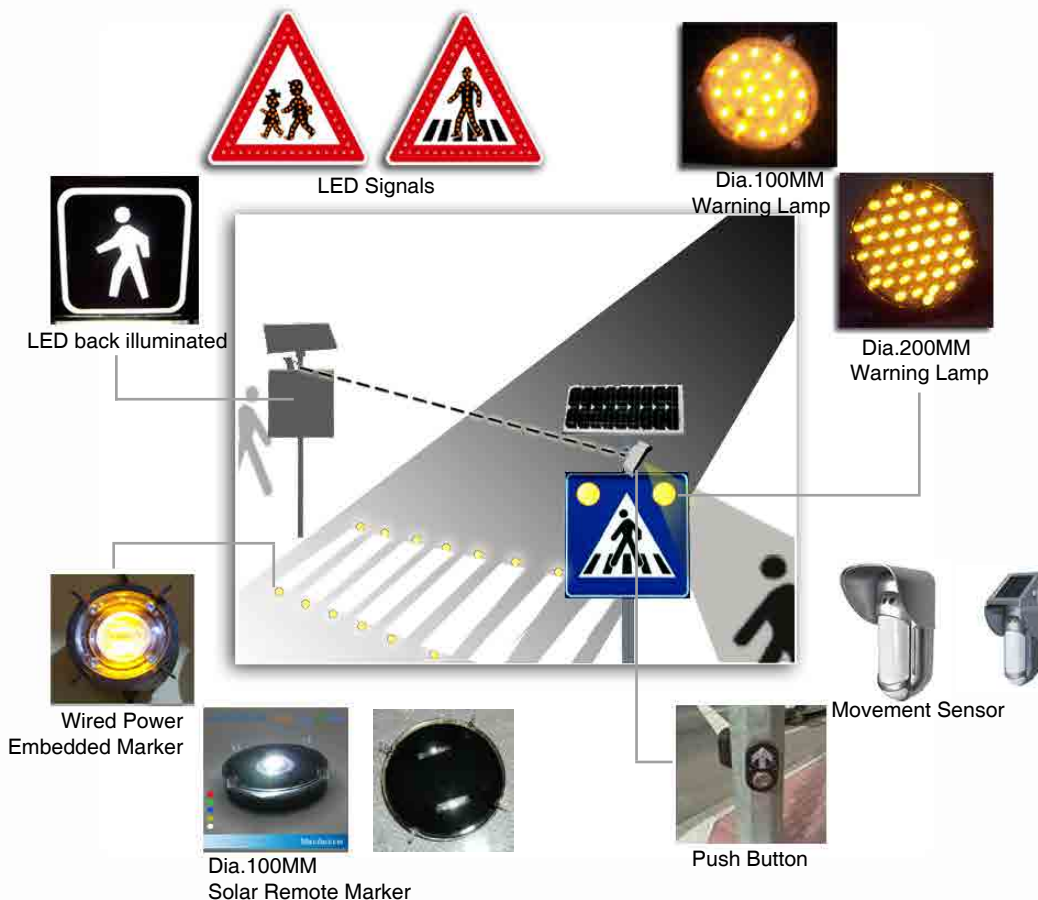

Product description:

This is a safety system for crosswalks with pedestrian radar and flashing lights
 The system start to work when a pedestrian approach to the crosswalks zone
 Solar power system or 12V DC (transferred from 220V) (Optional)
 Easy installation on existing signs
 Work with in-ground power markers and remote controlled solar marker

Product Construction:

- Remote control
- Movement detector
- Warning lamps / warning sign
- Solar / Wired embedded markers

Working mode:

When the movement of the cross walks is detected, there will be a signal sent out by the controller and all the warning lamps / warning signals and embedded markers will start to work (flashing). This will give a clear warning signal to the driver in advance to avoid an accident.

Item No. Reference:

- | | |
|---|--|
| B061 Controller | B0651 Wired power Dia.200mm Warning Lamp |
| B0621 Wired power Dia.100mm Warning Lamp | B0652 Solar Power Dia.200 Warning Lamp |
| B0622 Solar power Dia.100 Warning Lamp | B0661X Wired power LED Signals |
| B0631 Solar Embedded Marker Top 1 LED type | B0662X Solar Power LED Signals |
| B0632 Solar Embedded Marker 2 directions type | B0671 Wired power Movement Detector |
| B0641 Wired Power Embedded Marker | B0672 Solar Power Movement Detector |
| | B0673 Push Button |

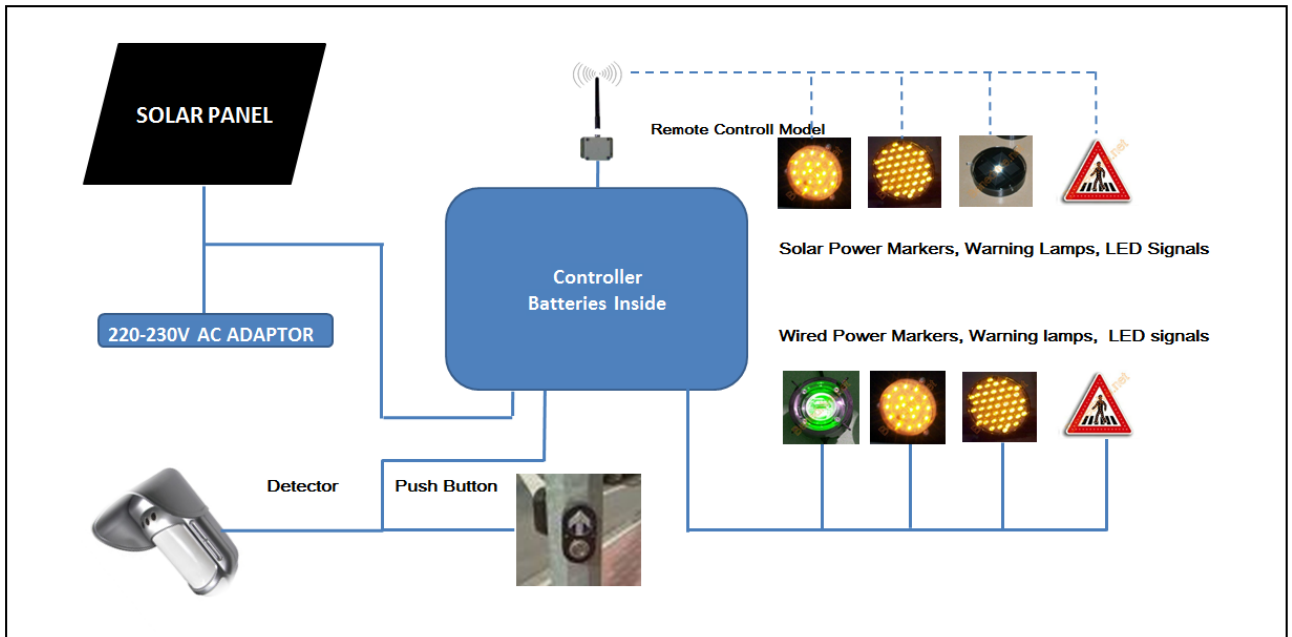

HOW TO ORDER:

One set include:

1. Controller (2pcs, each Includes the radio launcher and Movement detector)
2. Warning lamps (4 pcs, each sign need 2 pcs or according to need. Or using LED warning sign)
3. Solar embedded marker (5 pcs, Or wired embedded markers)

NOTE: Wired type or Solar powered type is according to your actual project need.

You can make the choice according to your special need, please see following diagram:

You can make any combination of wired and solar type for all above parts.

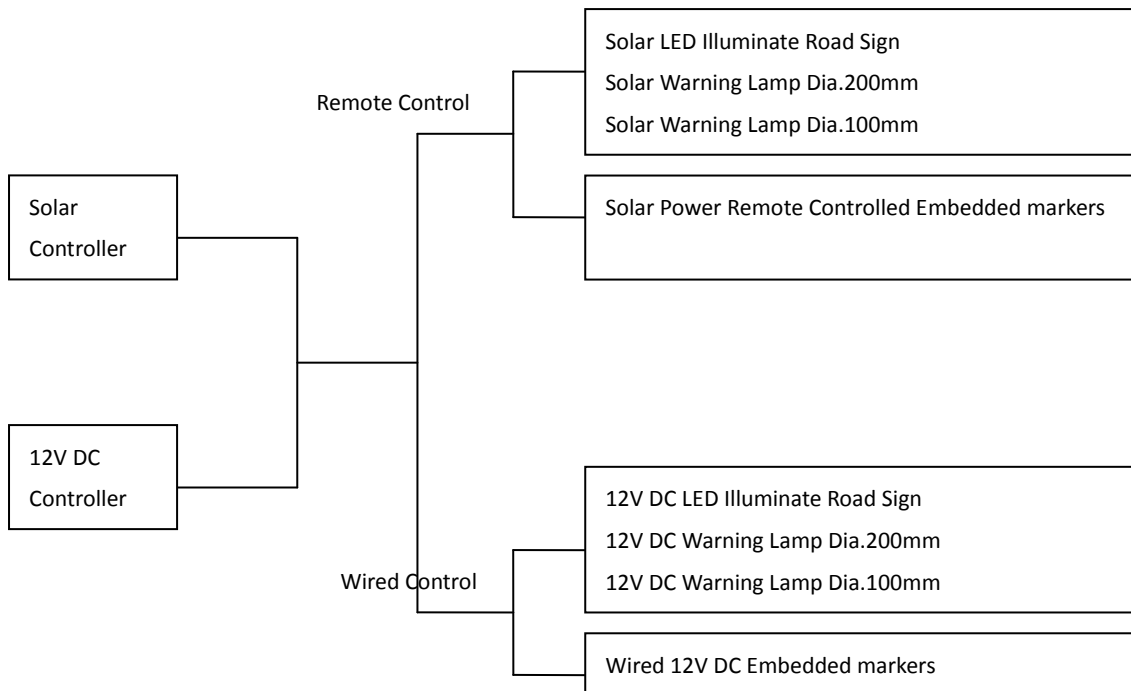

Item No: B04



Introductions:

There are two main concerns in tunnels: guidance and emergency. Small car Driver's visibility in front sometimes is limited when after a bigger truck, and easy to ignore the traffic lights' signals, especially in bad weathers such like foggy days, is insufficient.

There will be 2 bad effect ions:

1. Lower traffic flow
2. Traffic accidents

The driver need a clear view of the traffic signal or at least know the signals clearly even it is out of view. The idea place is at side of the drive's eyes. This may give the driver much longer time to make next actions, which could effectively reduce accidents and increase the traffic flow.

Now we have a solution.

Improved embedded road markers, could connected with the traffic signal controllers, and they could change and show the same color as the traffic signal as the right directions.

How it works:

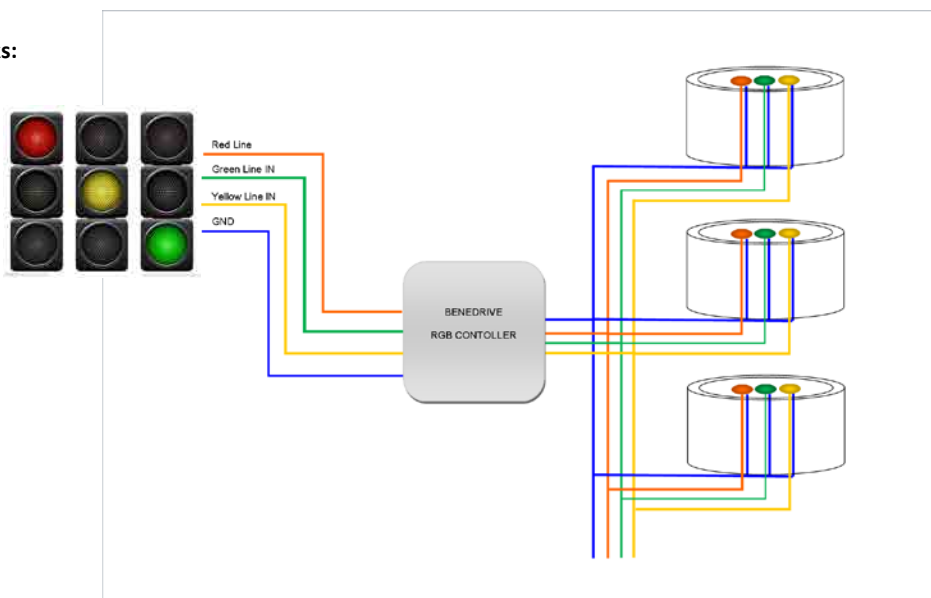

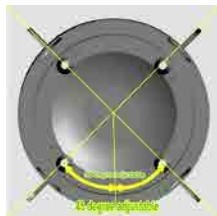

Key Feature:

1. Clear view over 1000 meters
2. Fast and easy installation
3. Embedded design, snow ploughable
4. LED directions adjustable even after installation, 45 degrees and 90 degree.

HOW TO ORDER:

One signal line one controller could run 50 pcs markers
 Controller: INPUT: 220V AC, OUTPUT: 12V DC
 Wired Marker: INPUT: 12V DC
 One controller could run upto 50 pcs markers

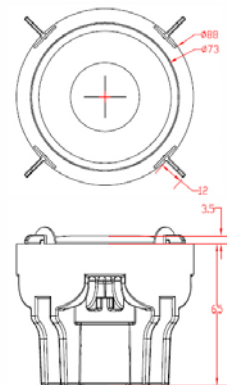

Installation Instructions

- 1 Connect the cables and markers
- 2 Saw cut cable trench, 5mm(Width) X 70mm (depth) (Width According to the diameter of the cable or tube will be used), Core drilling of holes, Dia.90mm X 70mm (depth)
- 3 Clean and dry holes and Trench
- 4 Fill glue to 1/3 of the depth
- 5 Pull cables and studs shell in
- 6 Fill more glue till flat to the road surface, clean the extra glue.
- 7 Now installation finished. The installation parts left their and will be moved off by wheels.

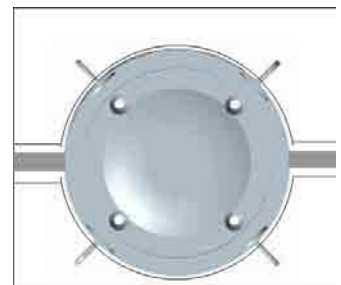
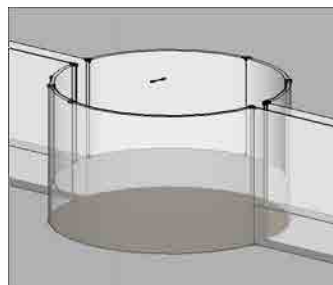
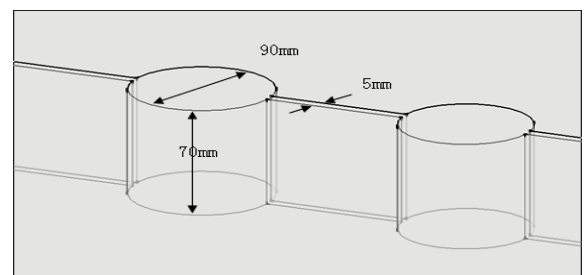

Item No: B051 Solar Delineator Markers



Purpose:

Cycling had been proved the best living life and most economical transport way to work and normal life. More and more cycle ways are under construction all over the world. Accordingly, cycle way safety is an urgent issue for all projectors and the governments. Benedrive's solar guidance marker is particular design for cycle way safety guidance purpose. And we supply a large range of products according to different areas and actual situations.

The solar guidance markers could give a clear view ahead of the cyclists from a long distance over 500 meters, which could give the cyclist much longer reaction time to the dangerous points. Benedrive's solar guidance markers could also be used to separate the motorway and cycle ways in the city.

Many projects had been proving that our guidance markers not only improve the cyclists' safety, but also could be architectural lights on the road.

Why Benedrive's is a better design:

1. Safe to the cyclings
 Only 3.5mm above the road surface, nearly no effect to the cycle wheel.
 Other designs: 8-30MM, will be a bad experience tot he cyclist. Big bump too dangerous.
2. Easier road surface meaintenance after installation
3. Long use life over 5 years

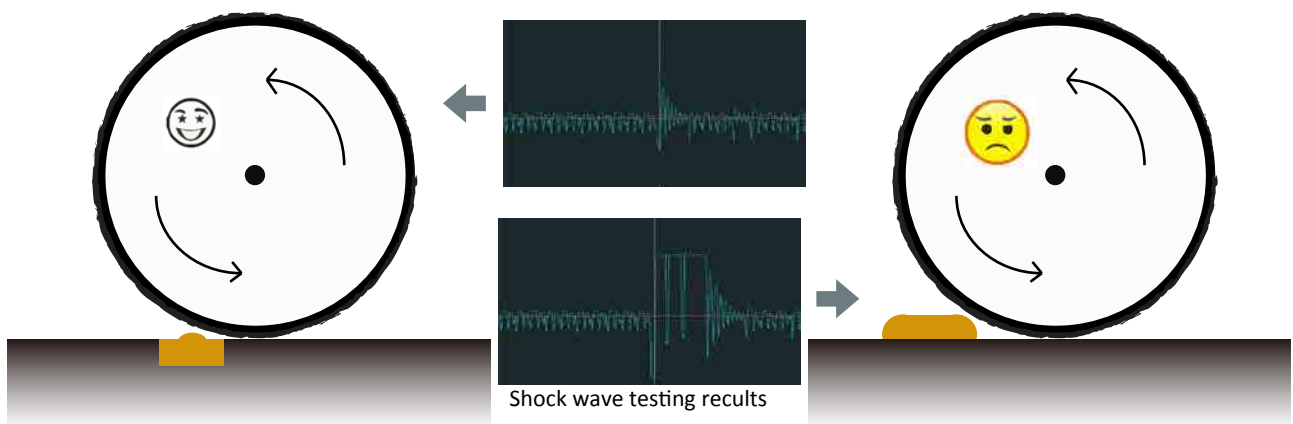



Key Feature:

1. Easy installation
2. No maintenance cost
3. Absolutely Safe design (Embedded design, only 3-5mm above the road surface, much lower than standard raised pavement markers. Raised pavement marker is over 20MM above the road surface, too high and too dangerous to the cyclist.)

Product Specifications:

Size: Dia.50MM, Dia.80MM, Dia.100MM.
 Light source: Supper bright LED
 View distance over 500 meters
 Power supply: Solar system and rechargeable batteries inside
 Full recharge time: 5-8 hours
 Working time: 50hours (Dia.50mm), 72 hours (dia.80mm), 100hours (dia.100mm)
 Activate mode: Automatically turn on when getting dark, (lower than 500lux)
 Work mode: Constant (flashing model available)
 Use life: over 5 years.



Dia.50MM



Dia.80MM



Dia.100MM

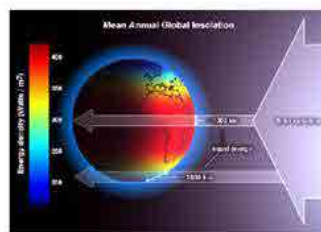
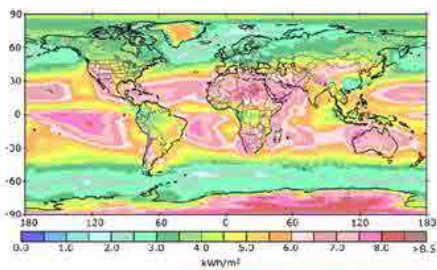

- >3.5hrs: Dia.50mm products
- >2.5hrs: Dia.80mm products
- >1.5hrs: Dia.100mm products

How to choose the right products

Item No: B0521 Active Safety Warning Signs

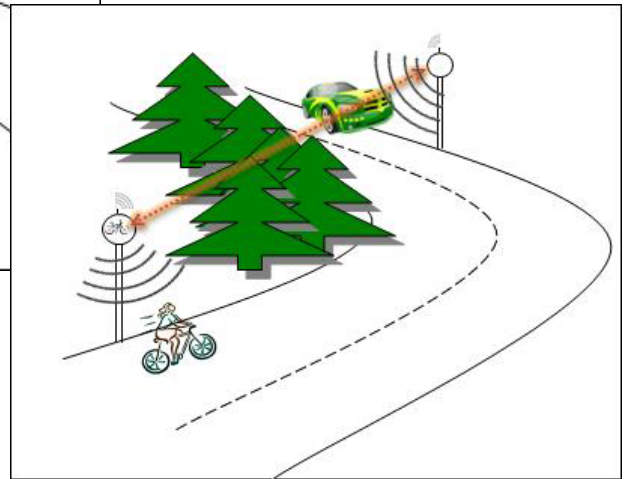
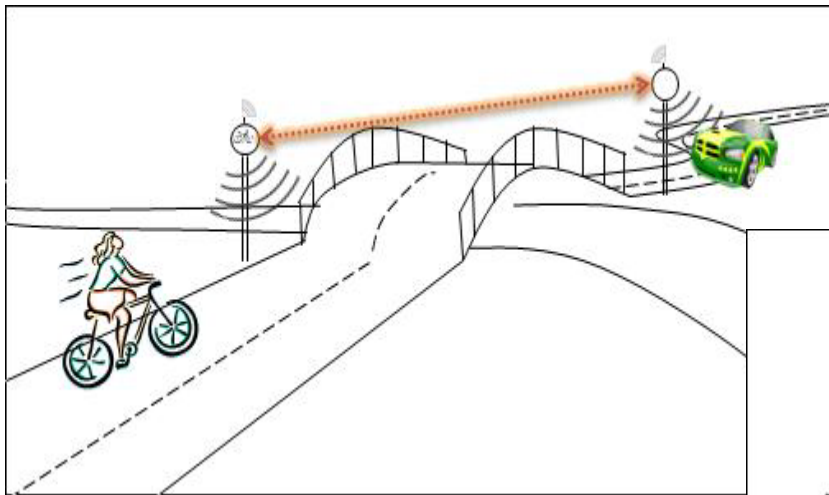

Purpose:

The bicycle warning sign alerts drivers that a cyclist is coming through the area by lighting up a LED bicycle. It can dramatically reduce the risk of cyclists not seen by passing motorists.

Key Feature:

- 1. Intelligent detective and remote activated
- 2. Solar system and long life time
- 3. Easy installation
- 4. Solar module can be adjusted to the most effective recharge position

Product Specifications:

Size: Dia.200mm
 Light: Supper bright LED
 Brightness: optional
 Power supply: Solar system and rechargeable batteries inside
 Battery type: Li-on batteries
 Full recharge time: 8 hours
 Working time: over 200 hours when fully recharged (Optional)
 Activate mode: Radar detector inside, activate other signs in the same area by remote
 Work mode: all signs flash 30 seconds when activated
 Installation: have installation accessories for dia.40mm tubes, no need other tools

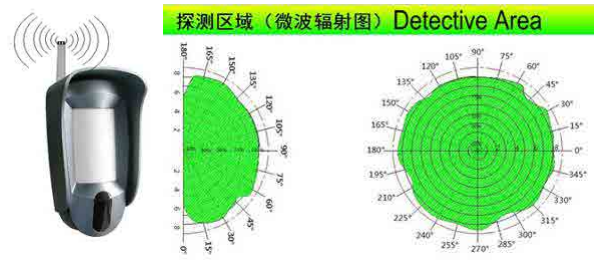

How to order:

One set includes 2 warning signs at least, the q'ty depends on the area need
 Package: 2 pcs/ carton, carton size: 220mm X 220mm X 125mm,
 G.W.: 3.5kgs/ctn

With detectors for Both Motorway and Cycleway
 Detector's Angle adjustable
 2 pcs flashing warning lamps Dia.100mm

Other model available:



B0522 Active Solar Warning Signs

Item No: B053 Solar Sensor Lighting

Purpose:

The Solar sensor lighting alerts cyclist that a there is a dangerous area must be noticed, and also could be used as a break post light and emergency power charging station for cell phones , lights and other electronics. It includes a USB adapter tobe easy connected to standard electronics.

Key Feature:

- 1. Intelligent detective
- 2. Solar power and environmental friendly
- 3. Easy installation

Product Specifications:

Size: Dia.200mm
 Light: Supper bright LED
 Lighting angle: 120 degree
 Power supply: Solar system and rechargeable batteries inside
 Battery type: Li-on batteries 3.2V 5Ah
 Activate mode: Movement sensor inside, activated working when cyclist comes closer with 6-10 meters range
 Work mode: 30 seconds lights after activated
 Easy installation onto standard post with 2 screws
 Package: 2 pcs/ carton, carton size: 220mm X 220mm X 50mm,
 G.W.: 2.2kgs/ctn

Applications:

- 1. Bad road surface situations
- 2. Obstacle and hazard working ahead
- 3. Bridge and Changing Tracks warning



Item No: B07



Purpose:

In the night time, the driver's vision is limited to the distance lighted by the car lights. Even reflectors are limited to the range that the car lights. So if you want the driver to notice any kind of markings from a long distance, it has to be lighted in itself. The most visible marking is the one contains illumination figures that light in the direction of the driver.

Benedrive supply 2 solutions:

1). Central controlled Wired Power markers

Key Features:

1. Automatic and intelligent :
Light sensor control turn on when getting dark lower 500LUX
2. Long life time : Use life over 8 years
3. Good performance, View distance over 800 meters
4. Synchronized or Sequential flashing both available for different situations.
5. Low maintenance cost

2). GPS controller Solar power markers

Key Features:

1. Automatic and intelligent : Light sensor control turn on when getting dark lower 500LUX
2. Long life time : Use life over 8 years
3. Good performance, View distance over 500 meters
4. Synchronized or Sequential flashing both available for different situations.
5. Low maintenance cost

How it works:

The lights flashing Synchronized or sequentially as the controller designed

1. Controller design: Synchronized Flashing Sequentially flashing:
5 push or 10 push (GPS model 5 pushed available only)
2. LED or Solar powered LED traffic circle sign Arrows flashing Clock wisely
Arrows Flashing Easterly
3. Solar GPS controller Lights , Controlled by GPS, designed inside the controller, no need other controllers, Work type: Synchronized flashing or Sequentially flashing



Solar LED Warning Signal



Solar GPS controlled LED Embedded Marker



Solar GPS controlled / Wired Power LED Raised Marker



Wired Power LED Embedded Marker

Item No: B03



There are two main concerns in tunnels: guidance and emergency. Driver's visibility in tunnel is very limited and normal reflective guidance, especially in emergency, is insufficient.

Temporary lane change and tube closure can create dangerous traffic situations, and emergency situations require high attention from drivers. Fire, smoke and chemical spills are the most hazardous emergency situation in tunnel. Impaired vision and disorientation may cause disaster to drivers and passengers trying to flee to safety.



We provide the solution for all possible applications for tunnel in-road guidance and emergency lighting:

1. Improve driver guidance
2. Improve guidance in all emergencies and increase reliability
3. Maintain lane separation both inside and on tunnel approaches
4. Enforce lane discipline; minimize clipping of curves
5. Complement the overhead lighting

What We Supply:



B031 Guidance marker controller



B0341 LED illuminate Singal



WPRS222
Road side Guidance Marker



WPRS215
Road side Guidance Marker



WPRS112
Central Lane Guidance Marker



WPRS212-2
Escape safety Guidance Marker



WPRS212
Road side Guidance Marker



WPRS214
Side Guidance Marker



BENEDRIVE CONTACTS

BENEDRIVE INTERNATIONAL CO., LTD.
SHENZHEN BENEDRIVE TECHNOLOGY CO., LTD.

TEL: +86 156 02901287 (Whatsapp)
+86 755 23290071

FAX: +86 755 23290072

E-mail: sales@benedrive.com

QQ: 363398022

ADD: F Blding, Baosheng industrial Park,
Laodong Erdui, Xixiang Town,
Baoan District, Shenzhen,
P.R.China